



# A Study of Simulation and Modeling of Three-Phase Electric Transformers

Salam Waley Shneen<sup>1,\*</sup> , Fadhil Mahmood Oleiwi<sup>2</sup> , Jaber. O. Dahloos<sup>3</sup> 

<sup>1,2</sup> Energy and Renewable Energies Technology Center, University of Technology, Baghdad, Iraq

<sup>3</sup> Centre for Research on Environment and Renewable Energy, University of Kerbela, Iraq

Email: <sup>1</sup> [salam.w.shneen@uotechnology.edu.iq](mailto:salam.w.shneen@uotechnology.edu.iq), <sup>2</sup> [fadhilphy@yahoo.com](mailto:fadhilphy@yahoo.com)

\*Corresponding Author

**Abstract**—Under the title “A Survey of Simulation and Modeling of a Three-Phase Electric Transformer,” the present work presents a proposed modeling and simulation process for two types of step-up and step-down transformers. To design and build the model, a suitable transformer specification must be established through mathematical representation. To conduct tests using MATLAB, the proposed tests are conducted for both step-up and step-down cases by varying the number of turns in the primary and secondary windings to a step-up ratio of up to ten times, from 300 V to 3000 V, and step-down to 150 V. Transformer considerations for both step-up and step-down cases include maintaining the number of turns in the primary winding at 100 turns, while for step-up, we use the number of turns in the secondary winding at 1000 turns, to obtain ten times the input voltage at the transformer output. In the second test case, the input voltage is 300 V, and the primary coil has 100 turns. Changing the secondary coil from 1,000 turns to 50 turns halves the transformer's input voltage, resulting in a voltage of 50 V. A set of tests can be tabulated to represent different cases suitable for multiple transformers that can be built for the same prototype, as well as to serve as a reference for future studies.

**Keywords**—Three-Phase; Transformer; Step-Up; Step-Down; Modeling

## I. INTRODUCTION

Electrical machines are those machines that operate with electrical energy and depend on specific amounts of electrical quantities [1], [2]. The electrical quantities associated with these machines give them size and meaning. Some operate with small quantities, others with large quantities, and each one has a specific name [3], [4]. We can talk about machines in three main types, which represent the generator, the motor, and the electrical transformer. Each machine has a specific function, including the one that produces electrical energy, which is the generator [5], [6]. The input source of the generator varies from one type to another, but the principle is the same: providing kinetic energy to the generator, enabling it to convert it and produce electrical energy according to the operating principle of the electrical generator. While there is a second machine, the electric motor, which is the machine that works in the opposite way to the generator, as it produces mechanical energy from the electrical energy supplied to the motor [7], [8]. In addition, there is a third type of machine, which is the electrical transformer [9], [10]. Its function is to change electrical quantities between the transformer's input side, which is the primary side, and its output side, which is called the secondary side [11], [12].

Transformers are of various types, and they can be classified according to function or phase, thus, they can be

identified [13], [14]. There are single-phase transformers and three-phase transformers, some of which are called step-up transformers and others are called step-down transformers. Transformers work to increase the electrical quantities connected to the primary terminal of the transformer to higher values in the secondary terminal and are called step-up transformers [15], [16]. Other transformers work in the opposite way, providing a lower quantity at the secondary terminal. The operation of the transformer depends on the magnetic field generated by applying voltage to the primary terminal. The magnitude of the field is determined by several factors, including the applied voltage and the specifications of the primary and secondary transformer coils. This depends on the length of the wires of the primary and secondary coils and their cross-sectional area [17], [18]. Therefore, the number of turns in the primary coil and the ratio of the number of turns in the primary and secondary coils give the relationship between the input and output of the transformer [19], [20]. When the number of turns in the primary coil is less than the number of turns in the secondary coil, the transformer increases the electrical quantities in the transformer output by the ratio of the number of turns in the secondary coil to the number of turns in the primary coil. By controlling the number of turns of the two coils, the transformer's function can be determined as step-up or step-down.

In [21], the study relied on learning using electronic computers using the engineering program MATLAB, and as an applied example, tests were conducted on electrical transformers. The study presented a conclusion indicating the possibility of identifying and verifying the effectiveness of the model using computer simulation to study and analyze the behavior of electrical transformers.

In [22], the study relied on a simulation model developed to identify the behavior of an electrical transformer was tested, including open and short circuits, and the test results were compared with mathematical calculations. The tests were conducted by electrical engineering students, with a survey taken to ensure reliability and enhance student understanding.

In [23], the study presented a model of an electrical transformer, demonstrating that it consists of a primary and secondary coil. It also highlighted the connection method between them, whereby they are magnetically connected via an inductive circuit, a magnetic circuit. It also demonstrated how transformers operate, based on the principle of efficient energy transfer via magnetic induction from one coil to

another using a changing magnetic field generated by alternating current. The design method was used to construct the magnetic circuit, and the magnetic path was organized by designing the transformer core, providing a suitable path for the magnetic field to obtain voltage between the coils, and providing inductance at both ends of the transformer. The simulation model was then used to calculate approximate circuit parameters, including primary coil resistances and secondary coil reactance, in addition to a resistance and reactance representing the core.

The study provides a research contribution on how to build a model of a three-phase transformer by representing the transformer mathematically, while proposing specific specifications that can be used to identify the transformer's behavior during testing. It can be detailed in axes, including the first axis, the mathematical representation of the three-phase transformer that show in Section II, the second axis, the three-phase transformer model that show in Section III, and the third axis, the selection of three-phase transformer specifications that show in Section IV.

## II. METHODOLOGIES

Industrial companies are interested in building and producing transformers, which motivates specialists to meet the demand for developing and designing electrical transformers. Many researchers have presented various procedures for the foundations of electrical transformer design in their research studies. These studies rely on the concepts and principles of transformer operation, starting with a simulation model covering the concept that the transformer is a device composed of two fixed coils, one of which is called the primary coil and the other is the secondary. Studies have indicated the principle of self-induction for transformer operation, and the amount of induction or magnetic flux is an influential factor in generating the amount of energy produced at the transformer output. In addition, the number of turns in each coil and the ratio between them is designed according to the manufacturer's request by determining several factors and variables, including the dimensions of the transformer and the transformer parts according to appropriate and specified specifications to provide the appropriate and required performance to meet the demand for energy produced at the transformer output. The optimal challenge is to develop a feasible design at a lower cost and relatively low weight, using materials of appropriate size to achieve high-performance operation. There are also transformers designed and produced for other purposes, such as training and teaching on examining and operating the electrical and magnetic circuits of the transformer, and installing sensors to read electrical quantities such as current. Effort and ability.

Testing is a method that helps verify the effectiveness of systems and their test models. It allows users to conduct multiple tests in a shorter time than real-time laboratory tests. The reason for choosing computer simulation is the widespread interest among academic institutions in developing it as a testing tool for models representing real-time systems. By mathematically representing electrical transformers, the objective of the study can be achieved. The mathematical representation aims to construct and design simulation models. It also aims to identify the magnetic

behavior of electrical transformers. Tests can be conducted to include transient operating conditions and compare the behavior with that in laboratory testing. By examining the behavior, guidelines can be developed regarding the physical components of the transformer that affect its behavior and those that do not and can be ignored because they do not affect the accuracy of the results. To evaluate the process, data from all test cases is documented in the construction and creation of prototypes and models that are designed based on the system behavior and transient testing. Examples of what was presented about electrical transformers in Source 1 included the presentation and construction of mathematical models of electrical transformers, including models of voltage transformers and current transformers, in addition to voltage transformers and coupling capacitors.

The mathematical representation of the electrical transformer is a step in building the model, and this is used in the simulation model to conduct tests. The researchers present their contributions to the study of electromagnetic oscillations in three-phase electrical transformers using a simplified model and simulation approach. A simulation model of a three-phase transformer can be constructed and designed by reviewing the mathematical representation of the proposed model according to specifications that include all components of the magnetic circuit for both the primary and secondary terminals of the transformer. The transformer's behavior can be examined and identified under steady-state and transient operating conditions. Tests can be conducted to identify the transformation ratio and its effect on the transformer's output electrical quantities.

The Fig. 1 represents an electrical transformer, which can be described as consisting of an iron core wound around six sets of coils to form the primary coils, which have three coils, each with 100 turns for this study. The secondary coils of the transformer could have 1000 turns in the first test to identify a step-up transformer, while they could have 50 turns in the second test for a step-down transformer, as preliminary testing suggestions.

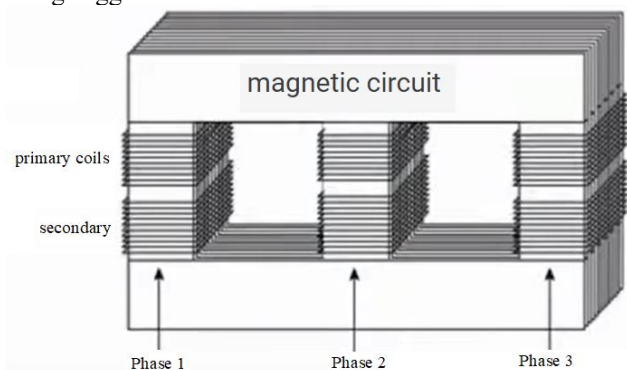

Fig. 1. Magnetic circuit of 3-ph electrical transformer

The electrical and magnetic components of a transformer can be symbolized on its primary and secondary terminals. The primary terminal is symbolized by P, and the associated components are the resistor  $R_P$ , the LP coil, and the number of turns  $N_P$ . They can also be written as numbers, with the first terminal being represented by a number 1 and the primary terminal, while the second terminal is represented by a number 2 or the letter S, which represents the secondary terminal. To write the mathematical equations for the three

phases, the first phase is 1 if the number is chosen as the primary symbol, while P is 1 (p1, p2, p3) if the letter is chosen. A number must be added to distinguish between the phases, as in the following equations:

First, the electrical and magnetic components of a transformer can be written into the equations of the primary part as shown in Eqs. (1) to (6) [24]:

Equation (1) is the relationship of Phase 1, Equation (2) is the relationship of Phase 2, and Equation (3) is the relationship of Phase 3, while the other equations represent the effect of the number of turns on induction and magnetism.

$$U_1 = U_{p1} = RI_1 + N_1 \frac{d\phi_1}{dt} = RI_{p1} + N_{p1} \frac{d\phi_{p1}}{dt} \quad (1)$$

$$U_2 = U_{p2} = RI_2 + N_2 \frac{d\phi_2}{dt} = RI_{p2} + N_{p2} \frac{d\phi_{p2}}{dt} \quad (2)$$

$$U_3 = U_{p3} = RI_3 + N_3 \frac{d\phi_3}{dt} = RI_{p3} + N_{p3} \frac{d\phi_{p3}}{dt} \quad (3)$$

$$N_{p1} \frac{d\phi_{p1}}{dt} = L \frac{dI_{p1}}{dt} + M \frac{dI_{s1}}{dt} = N_1 \frac{d\phi_1}{dt} = L \frac{dI_1}{dt} + M \frac{dI_2}{dt} \quad (4)$$

$$N_{p2} \frac{d\phi_{p2}}{dt} = L \frac{dI_{p2}}{dt} + M \frac{dI_{s2}}{dt} = N_2 \frac{d\phi_2}{dt} = L \frac{dI_2}{dt} + M \frac{dI_1}{dt} \quad (5)$$

$$N_{p3} \frac{d\phi_{p3}}{dt} = L \frac{dI_{p3}}{dt} + M \frac{dI_{s3}}{dt} = N_3 \frac{d\phi_3}{dt} = L \frac{dI_3}{dt} + M \frac{dI_1}{dt} \quad (6)$$

Second, the electrical and magnetic components of a transformer can be written to include the secondary part equations as shown in Eqs. (7) to Eq. (12) following [21]:

Equation (7) is the relationship of Phase 1, Equation (8) is the relationship of Phase 2, and Equation (9) is the relationship of Phase 3, while the other equations represent the effect of the number of turns on induction and magnetism.

$$\dot{U}_1 = -R\dot{I}_1 + N_2 \frac{d\phi_1}{dt} \quad (7)$$

$$\dot{U}_2 = -R\dot{I}_2 + N_2 \frac{d\phi_2}{dt} \quad (8)$$

$$\dot{U}_3 = -R\dot{I}_3 + N_2 \frac{d\phi_3}{dt} \quad (9)$$

$$N_2 \frac{d\phi_1}{dt} = \dot{L} \frac{dI_1}{dt} + M \frac{dI_2}{dt} \quad (10)$$

$$N_2 \frac{d\phi_2}{dt} = \dot{L} \frac{dI_2}{dt} + M \frac{dI_1}{dt} \quad (11)$$

$$N_2 \frac{d\phi_3}{dt} = \dot{L} \frac{dI_3}{dt} + M \frac{dI_1}{dt} \quad (12)$$

The components and parameters of a three-phase transformer can be represented as shown in Fig. 2, and through them, mathematical relationships were written, and a simulation model was built that helps in identifying the system's behavior during the tests that were proposed to implement the research contributions in this study.

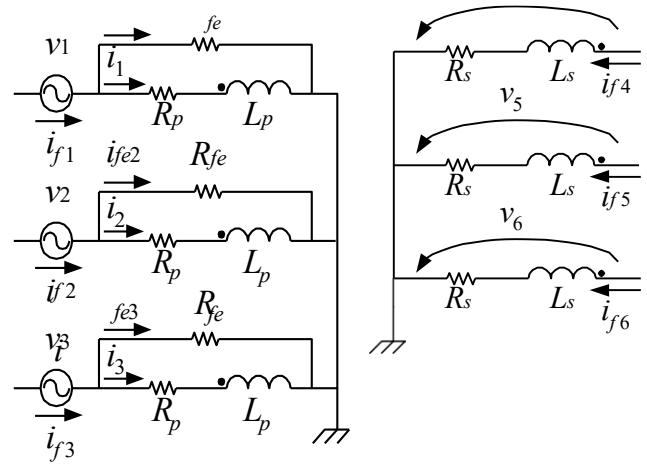

Fig. 2. Components and parameters for the primary and secondary terminals of a three-phase transformer

### III. SIMULATION

There are also other types of converters called electronic converters, and studies have been conducted on them, such as the single-phase and three-phase inverter, the rectifier converter, and other types of step-up converters that operate on the same type of electrical current. Computer simulations to understand the behavior of systems include all types of electrical machines. Other researchers have presented simulation models other than transformers, including those for electric motors and electronic converters to operate systems for various applications such as electric cars, electric elevators, communication and internet systems, and others.

Simulation and response include the simulation model of electrical and magnetic components of a transformer and the simulation results.

#### A. Simulation Model of Electrical and Magnetic Components for a Transformer

After representing the transformer mathematically, it is also necessary to determine its electrical and magnetic circuit specifications. This can be represented as a simulation model, as in Fig. 3.

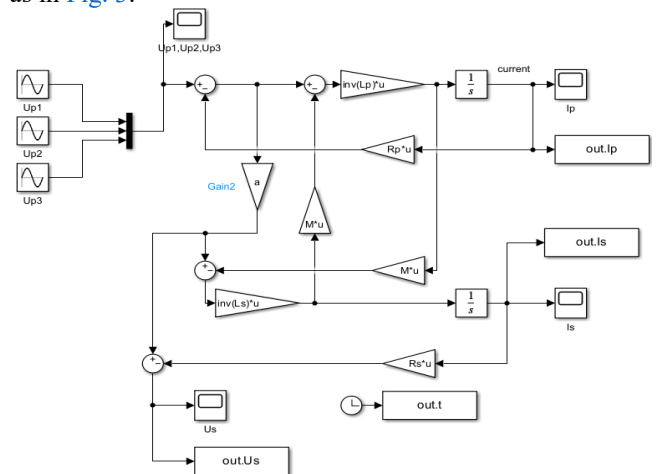

Fig. 3. Simulation model of electrical and magnetic components of a transformer

Fig. 3 represents a simulation model for defining the parameters of the electrical and magnetic circuit, where the

system properties are represented and written in M-file format as in the Fig. 4:

```

1  clc;clear all;close all;
2  Up=220*sqrt(2)
3  N1=100;
4  N2=1000;
5  a=N2/N1;
6  R1=1.15;
7  R2=11.5;
8  Rp=[R1 0 0; 0 R1 0; 0 0 R1]
9  Rs=[R2 0 0; 0 R2 0; 0 0 R2]
10 L1=0.0156;
11 L2=(N2^2)*(L1/N1^2)
12 Lp=[L1 0 0; 0 L1 0; 0 0 L1]
13 Ls=[L2 0 0; 0 L2 0; 0 0 L2]
14 M=0.49
15 M=[M 0 0; 0 M 0; 0 0 M]
    
```

Fig. 4. M-file for parameters of the electrical and magnetic circuit

Fig. 4 represents a simulation model for defining the parameters of an electric and magnetic circuit. The system properties are represented in workspace format, as shown in Fig. 5.

Workspace	
Name ^	Value
a	10
L1	0.0156
L2	1.5600
Lp	[0.0156,0,0;0,0.01...
Ls	[1.5600,0,0;0,1.56...
M	[0.4900,0,0;0,0.49...
N1	100
N2	1000
out	1x1 SimulationO...
R1	1.1500
R2	11.5000
Rp	[1.1500,0,0;0,1.15...
Rs	[11.5000,0,0;0,11....
Up	311.1270

Fig. 5. Workspace of electrical and magnetic components of a transformer

Fig. 5 represents a simulation model for defining the parameters of an electric and magnetic circuit. The system properties are represented in command window format, as shown in Fig. 6.

**B. Simulation Response of Electrical and Magnetic Components of a Transformer**

Using the simulation model in Fig. 3, in addition to using the M-File profile, the proposed test cases can be implemented, which include the set-up and set-down. The first test suggested a voltage of (311,1270=Up) volts for each phase, considering that the phase voltage was calculated in the second step of the M-File relationship in the form (Up=220\*sqrt(2)). The number of turns was also chosen at varying ratios to conduct several tests, which are listed with the simulation results in Table 1.

Table 1. Step-up transformer (N1<N2)

N2	N1	U1(V)	U2(V)	I1(A)	I2(A)
1000	100	311.1270	3111.270	15.28	1.528
800	100	311.1270	2500	12.86	1.609
600	100	311.1270	1865	10.17	1.695
400	100	311.1270	1244	7.164	1.791
300	100	311.1270	933.5	5.523	1.841
200	100	311.1270	622.5	3.753	1.877

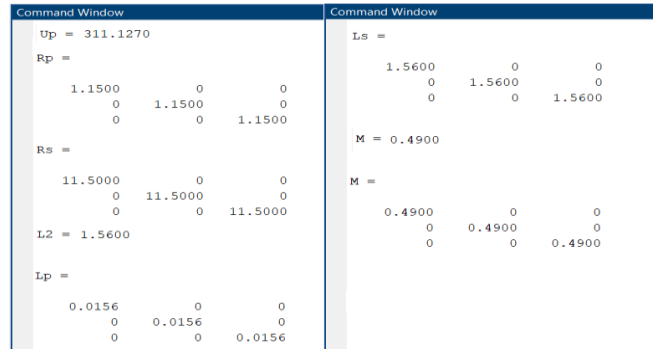

Fig. 6. Command window of electrical and magnetic components of a transformer

Table 1 represents the system response in proposed test cases for a lever-type transformer with ratios where the number of turns in the secondary coil is greater than the number of turns in the primary coil. A proposed primary coil with 100 turns was used, while tests for this type of transformer are conducted with several turns. The first test case included ten times the number of turns in the primary coil, bringing it to 1,000 turns. This allows for verifying the feasibility of increasing the transformer's input voltage by a factor of ten. Other ratios were also proposed, including test cases where the number of turns in the primary coil itself was 100 turns, while the transformation ratio changed with the number of turns in the secondary coil. These were 800 turns, 600 turns, 400 turns, and 300 turns, in addition to a test case with a ratio of twice the voltage. From the simulation results and by reading the electrical quantities for both the input and output terminals, the following can be concluded:

Firstly, an increase in the output voltage depends on the ratio of the number of turns in the secondary coil to the number of turns in the primary coil. Secondly, the results recorded a change in the transformer's input current value with a change in the transformer's output current value, with the input voltage remaining constant. Thirdly, in the step-up transformer, we find that when the transformation ratio is changed, an increase in the output current can be observed while the input current decreases.

Table 2 represents the system response in proposed test cases for a step-down transformer with ratios where the number of turns in the secondary coil is less than the number of turns in the primary coil. The proposed secondary coil has a 100-turn winding, while tests are being conducted for this type of transformer. The transformation ratio changes with the number of turns in the primary coil, which were 800 turns, 600 turns, 400 turns, and 300 turns, in addition to a test case with a half-voltage ratio.

From the simulation results and by reading the electrical quantities for both the input and output terminals, we can conclude the following:

Firstly, a decrease in the output voltage depends on the ratio of the number of turns in the secondary coil to the number of turns in the primary coil. Secondly, the results record a change in the transformer input current value with a change in the transformer output current value, while the input voltage remains constant. Thirdly, in the step-down transformer, we find that when the transformation ratio is changed, an increase in the input current can be observed while the output current decreases.

Table 2. Step-down transformer ( $N1 > N2$ )

N1	N2	U1(V)	I1(A)	U2(V)	I2(A)
1000	100	311.1270	0.042	31.11	0.42
800	100	311.1270	0.063	38.89	0.51
600	100	311.1270	0.108	51.85	0.648
400	100	311.1270	0.221	77.78	0.884
300	100	311.1270	0.3592	103.7	1.078
200	100	311.1270	0.6813	155.5	1.363

A test case was chosen to plot the current and voltage signals for the input and output of the electrical transformer, as shown in Fig. 7, Fig. 8, Fig. 9 to Fig. 10. Fig. 7 shows the primary voltage at run time 1 sec and the primary voltage at run time 0.02 sec for the step-up transformer. Fig. 8 shows the secondary voltage at run time 1 sec and the secondary voltage at run time 0.02 sec for the step-up transformer. Fig. 9 shows the primary current at run time 1 sec and the primary current at run time 0.02 sec for the step-up transformer. Fig. 10 shows the secondary current at run time 1 sec and the secondary current at run time 0.02 sec for the step-up transformer.

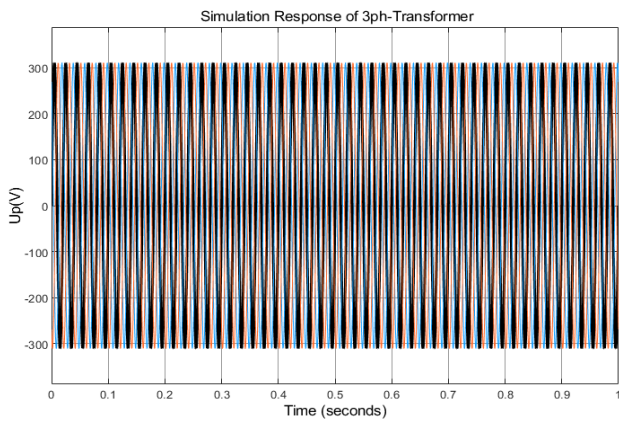

a. Primary voltage at run time 1 sec

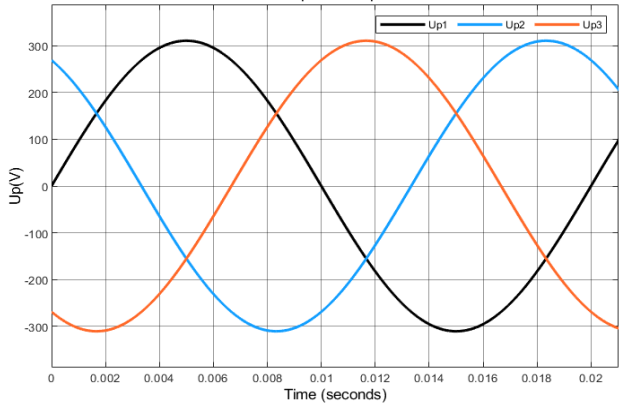

b. Primary voltage at run time 0.02 sec

Fig. 7. Primary voltage for step-up transformers

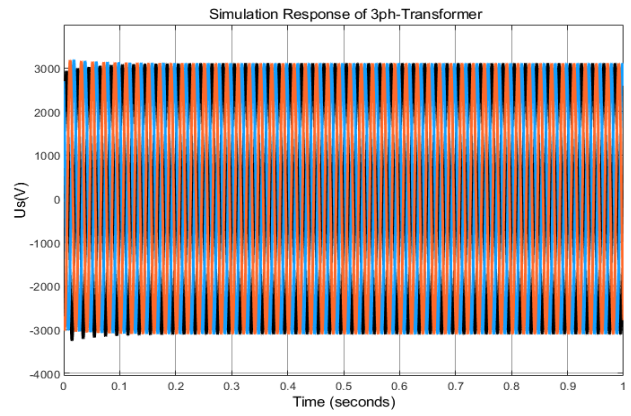

a. Secondary voltage at run time 1 sec

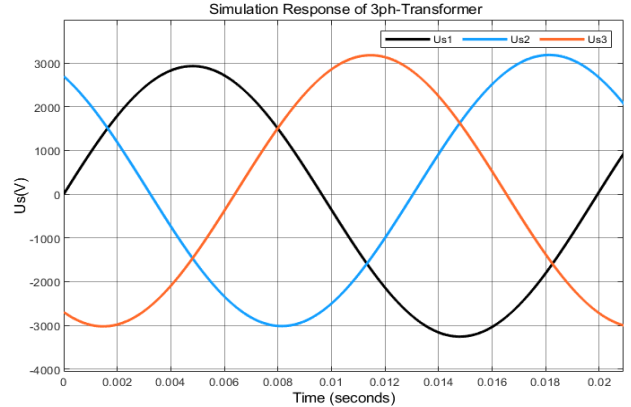

b. Secondary voltage at run time 0.02 sec

Fig. 8. Secondary voltage for step-up transformer

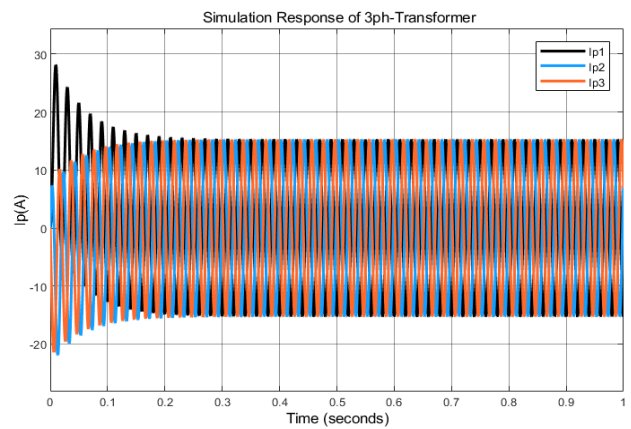

a. Primary current at run time 1 sec

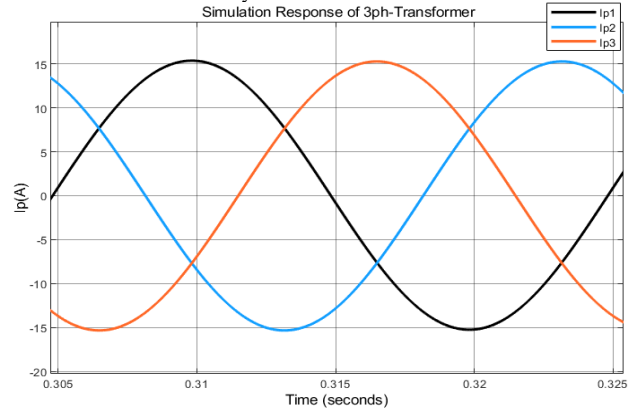

b. Primary current at run time 0.02 sec

Fig. 9. Primary current for step-up transformers

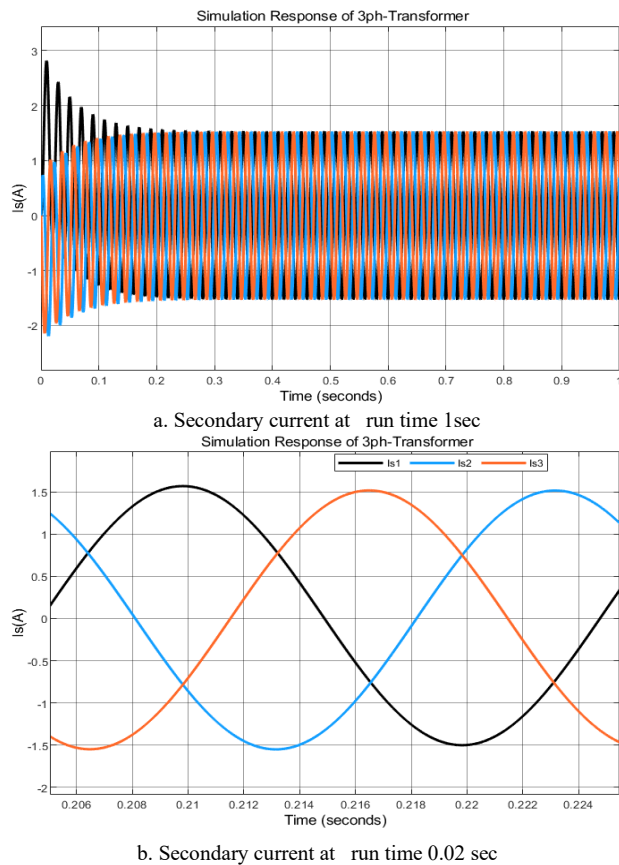

Fig. 10. Secondary current for step-up transformer

#### IV. CONCLUSION

Based on study and design of a simulation model were proposed to identify the mathematical electrical transformer system. A simulation model was also developed to verify the feasibility of analyzing its behavior when operating as a step-up or step-down transformer. The feasibility of achieving the required transformer output was verified, which can be adopted in future studies. By varying the number of turns in the primary and secondary coils, the transformation ratio can be determined. The parameters of the system's input and output current changes can also be determined, as demonstrated by the simulation results.

#### REFERENCES

- [1] A. O. Ajayi, O. C. Maryjane, A. Emmanuel, C. Nwanevu, "Sustainability in transformer manufacturing: The role of renewable energy in automating coil winding machines," *World Journal of Advanced Research and Reviews*, vol. 25, no. 01, pp. 957-976, 2025, <https://doi.org/10.30574/wjarr.2025.25.1.0033>.
- [2] Z. A. Al-Dabbagh, S. W. Shneen, and A. O. Hanfesh, "Fuzzy Logic-based PI Controller with PWM for Buck-Boost Converter," *Journal of Fuzzy Systems and Control*, vol. 2, no. 3, pp. 147-159, 2024, <https://doi.org/10.59247/jfsc.v2i3.239>.
- [3] D. A. Tziouvaras *et al.*, "Mathematical models for current, voltage, and coupling capacitor voltage transformers," *IEEE Transactions on Power Delivery*, vol. 15, no. 1, pp. 62-72, 2000, <https://doi.org/10.1109/61.847230>.
- [4] M. Figueroa, G. de Jesús, "Modeling and characterization of single-phase and three-phase transformers based on minimum information," *Doctorat en Ingeniería Eléctrica*, p. 186, 2024, <https://www.tesisenred.net/handle/10803/690618?page=1>.
- [5] Z. A. Al-Dabbagh, S. W. Shneen, and A. O. Hanfesh, "Fuzzy Logic-based PI Controller with PWM for Buck-Boost Converter," *Journal of Fuzzy Systems and Control*, vol. 2, no. 3, pp. 147-159, 2024, <https://doi.org/10.59247/jfsc.v2i3.239>.
- [6] S. Waley, C. Mao, N. K. Bachache, "Biogeography based optimization tuned fuzzy logic controller to adjust speed of electric vehicle," *TELKOMNIKA Indonesian Journal of Electrical Engineering*, vol. 16, no. 3, pp. 509-519, 2015, <http://doi.org/10.11591/tjee.v16i3.1642>.
- [7] S. Waley, S. Waley, C. Mao, N. K. Bachache, "Biogeography based optimization for tuning FLC controller of PMSM," *Advances in Swarm and Computational Intelligence*, pp. 395-402, 2015, [https://doi.org/10.1007/978-3-319-20466-6\\_42](https://doi.org/10.1007/978-3-319-20466-6_42).
- [8] S. W. Shneen, A. L. Shuraiji, "Simulation model for pulse width modulation-voltage source inverter of three-phase induction motor," *International Journal of Power Electronics and Drive Systems*, vol. 14, no. 2, pp. 719-726, 2023, <http://doi.org/10.11591/ijpeds.v14.i2.pp719-726>.
- [9] S. W. Shneen, Z. B. Abdullah, and H. S. Dakheel, "Design and Implementation of Voltage Source Inverter Using Sinusoidal Pulse Width Modulation Technique to Drive A Single-Phase Induction Motor," *International Journal of Robotics and Control Systems*, vol. 4, no. 4, pp. 1527-1546, 2024, <https://doi.org/10.31763/ijrcs.v4i3.1541>.
- [10] R. T. Ahmedhamdi, S. W. Shneen, "Using position control to improve the efficiency of wind turbine," *TELKOMNIKA (Telecommunication Computing Electronics and Control)*, vol. 18, no. 6, pp. 3240-3246, 2020, <http://doi.org/10.12928/telkomnika.v18i6.16171>.
- [11] S. W. Shneen, M. A. A. Hussein, J. A. Kadhum, and S. M. Ali, "Application of LFAC {16 2/3Hz} for electrical power transmission system: a comparative simulation study," *TELKOMNIKA (Telecommunication Computing Electronics and Control)*, vol. 17, no. 2, pp. 1055-1064, 2019, <http://doi.org/10.12928/telkomnik.v17i2.10353>.
- [12] J. A. Kadhum, S. W. Shneen and M. A. A. Hussein, "Utilization of DC motor-AC generator system to convert the solar direct current into 220v alternating current," *International Journal of Computer Applications Science*, vol. 5, no. 3, pp. 391-396, 2018, [https://maqsurah.com/home/item\\_detail/79743](https://maqsurah.com/home/item_detail/79743).
- [13] Z. A. Al-Dabbagh and S. W. Shneen, "Design of a PID speed controller for BLDC motor with cascaded boost converter for high-efficiency industrial applications," *International Journal of Robotics and Control Systems*, vol. 5, no. 1, pp. 22-46, 2025, <https://doi.org/10.31763/ijrcs.v5i1.1601>.
- [14] S. W. Shneen, F. N. Abdullah, and D. H. Shaker, "Simulation model of single phase PWM inverter by using MATLAB/Simulink," *International Journal of Power Electronics and Drive Systems*, vol. 12, no. 1, pp. 212-216, 2021, <http://doi.org/10.11591/ijpeds.v12.i1.pp212-216>.
- [15] A. A. Mutlag M. K. Abd and S. W. Shneen, "A comparative investigation of hybrid MPPT methods for enhancing solar power generation in renewable energy systems," *International Journal of Electrical and Electronics Research*, vol. 12, no. 3, pp. 991-1000, 2024, <https://ijeer.forexjournal.co.in/archive/volume-12/ijeer-120333.html>.
- [16] A. A. Mutlag, M. K. Abd, and S. W. Shneen, "Power management and voltage regulation in DC microgrid with solar panels and battery storage system," *Journal of Robotics and Control (JRC)*, vol. 5, no. 2, pp. 397-407, 2024, <https://doi.org/10.18196/jrc.v5i2.20581>.
- [17] P. Karpov, G. Godin, and I. V. Tetko, "A transformer model for retrosynthesis," *Proceedings of the International Conference on Artificial Neural Networks*, pp. 817-830, 2019, [https://doi.org/10.1007/978-3-030-30493-5\\_78](https://doi.org/10.1007/978-3-030-30493-5_78).
- [18] E. I. Amoralis, M. A. Tsili and A. G. Kladas, "Transformer Design and Optimization: A Literature Survey," *IEEE Transactions on Power Delivery*, vol. 24, no. 4, pp. 1999-2024, 2009, <https://doi.org/10.1109/TPWRD.2009.2028763>.
- [19] D. Friedman, A. Wettig, and D. Chen, "Learning transformer programs," *ArXiv*, 2023, <https://doi.org/10.48550/arXiv.2306.01128>.
- [20] R. Agarwal, H. Li, Z. Guo and P. Cheetham, "The Effects of PWM With High dv/dt on Partial Discharge and Lifetime of Medium-Frequency Transformer for Medium-Voltage (MV) Solid State Transformer Applications," *IEEE Transactions on Industrial Electronics*, vol. 70, no. 4, pp. 3857-3866, 2023, <https://doi.org/10.1109/TIE.2022.3174243>.

- [21] A. Koochaki, "Teaching calculation of transformer equivalent circuit parameters using MATLAB/Simulink for undergraduate electric machinery courses," *Indian Journal of Science and Technology*, vol. 8, no. 17, pp. 1-6, 2015, <https://doi.org/10.17485/ijst/2015/v8i17/59182>.
- [22] A. H. M. Nordin, R. F. Mustapa, M. E. Mahadan, N. H. Ahmad and N. Y. Dahlan, "Transformer interactive learning tool based on MATLAB Simulink and GUI," *2017 IEEE 9th International Conference on Engineering Education (ICEED)*, pp. 42-47, 2017, <https://doi.org/10.1109/ICEED.2017.8251162>.
- [23] N. Patil and J. H. Patil, "Design and analysis of transformer using MATLAB," *International Journal of Science Technology and Engineering*, vol. 4, no. 1, pp. 122-124, 2015, [https://www.worldwidejournals.com/international-journal-of-scientific-research-\(IJSR\)/article/design-and-analysis-of-transformer-using-matlab/NDYzOQ==/?is=1&b1=9&k=3](https://www.worldwidejournals.com/international-journal-of-scientific-research-(IJSR)/article/design-and-analysis-of-transformer-using-matlab/NDYzOQ==/?is=1&b1=9&k=3).
- [24] S. Lotfifard, "Teaching electrical model of power transformers to undergraduate students: Magnetic circuit approach," *arXiv*, 2021, <https://doi.org/10.48550/arXiv.2103.17257>.